



LUOcean

LU09xxC230-E Diode Laser
Up to 230W c.w. Operating Power @ 9xxnm



Description:

The LU09xxC230-E **LUOcean** series offers an optical output power of up to 230W in c.w. operation from a 600µm core diameter, NA 0.22 fiber. The device consists of multiple single emitter laser diodes in a rugged industrial package. Long lifetime is ensured due to laser diode facet passivation, extensive burn-in testing and screening of the individual single emitters. The performance makes it a valuable tool for various applications.

Features & Functions:

- Wavelength 915, 940 or 980nm
- burn-in tested single emitters
- 600µm, NA 0.22 Fiber
- SMA905 Connector
- Sealed housing
- Small foot print
- Temperature sensor option
- Red pilot laser option
- Water cooling option

Benefits:

- OEM quantities
- Ultra long Lifetime
- Cost effective
- High Efficiency

Applications:

- Pumping
- Illumination
- Material processing

Module Drawing (Dimensions in mm)

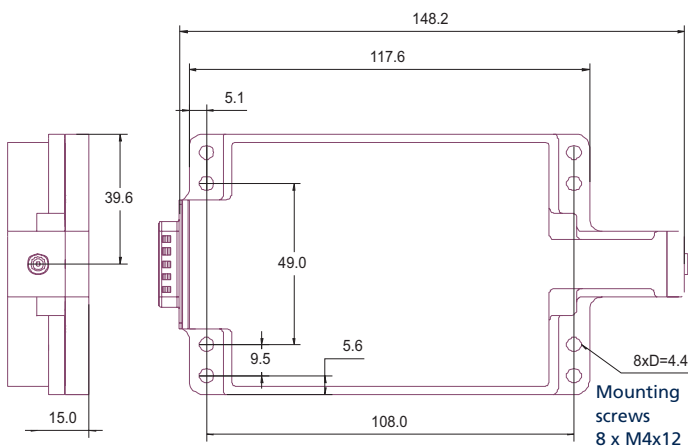

Ferrule Drawing (mm)

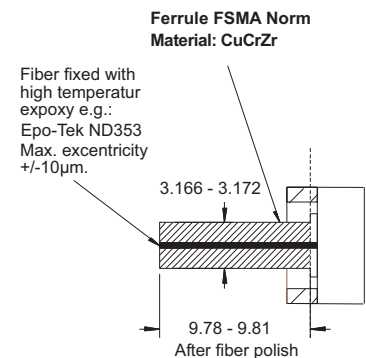

Pin Connections

Pin	Function
A1	Laser diode cathode (-)
A2	Laser diode anode (+)
1	Temp sensor LM 35, or NTC, or PT1000 *
2	Pilot laser anode (5V)*
3	GND: Temp sensor, Pilot, and monitor PD
4	Supply Volt.: +5V (LM 35, Monitor cathod) *
5	Monitor PD signal*

* Options

7w2 male Power and Signal Connector

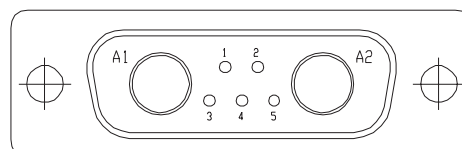

Your ideas are welcome.

Electrical and Optical Characteristics Laser specifications at 25°C

Parameter	Conditions	Symbol	Min	Typ	Max	Unit
LU09xxC230-E						
Output Power (2)	c.w.	P_{op}		230		W
Operating Current	c.w.	I_{op}		28		A
Peak Output Power (1) (2)	pulsed	$P_{op/pulse}$		300		W
Peak Current (1)	pulsed	$I_{op/pulse}$		36		A
Peak Wavelength	LU0915C230	λ	905	915	925	nm
	LU0940C230	λ	930	940	950	nm
	LU0975C230	λ	965	975	985	nm
Spectral Width (FWHM)		$\Delta\lambda$		4	8	nm
Threshold Current		I_{th}		2		A
Operating Voltage		V_f		20		V
Conversion efficiency				40		%
Wavelength Tuning vs. Temperature		λ / T		0.35		nm / K
Wavelength Tuning vs. Operating Current		λ / I		1		nm / A
Output Fiber (SMA905 connector on module)						
Core Diameter of output fiber		d_{core}	600			μm
Fiber centricity			10			μm
Numerical Aperture		NA		0.22		
Options:						
Option 1: Red pilot laser (2)						
C.W. Output Power				1.0	10	mW
Peak Wavelength			620	635	650	nm
Operating Voltage				5	10	V
Option 2: Water Cooling Base Plate						
Water Temperature		T	+10		+40	°C
Water Quality			Industrial Water, no DI-water, filtered particle size <0.1mm			
Water flux			1.5			l/min

Remarks:

- (1) Max. pulse time <300µsec, duty cycle <2%
- (2) With the red pilot option the c.w. and pulsed maximum optical output power (and consequently the operating current) is reduced by 9%
- (3) Back reflection is considered as 10ns pulse with 5% d.c. max. Back reflection filter which provides higher max. back reflection energy of 2mJ is offered on request.

Important Note

Read and carefully follow operating manual instructions. Especially, whenever power supply is switched on or off, always disconnect from laser module. See manual for details. Uncontrolled on / off switching may cause spikes and result in fatal device damage..

Absolute Maximum Ratings / General Informations

Parameter	Symbol	Min	Max	Unit
Storage Temperature	T_{max}	-15	+55	°C
Operating Temp. c.w.-operation	$T_{op.c.w.}$	+5	+35	°C
	pulsed operation (1) $T_{op.pulse}$	+5	+45	°C
Max Forward Current (c.w.)	I_{max}		30	A
Max Pulse Peak Current (1)	$I_{max.pulse}$		38	A
Humidity / non Condensing Atmosphere			90	%
Recommended Thermal Heatsink Resistance			0.03	K/W
LD Reverse Voltage	$V_{R,max}$		10	V
Weight			850	g
Mounting Screws / metric		8 x M4 x 12		mm
Max. back reflection of intrinsic pump wavelength output power			20	%
Max. back reflection, any other than λ of this diode laser (3)			10	μJ

To Option 2:
Dimensions of water cooling plate (mm)
Water flow rate should be >1.5l/min.

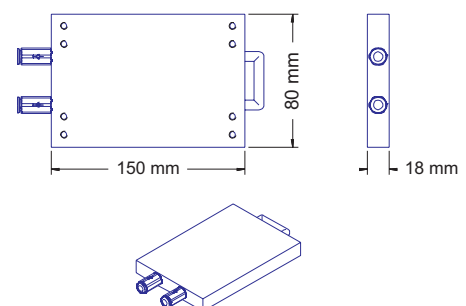

User Safety

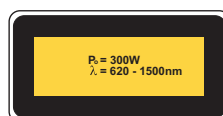
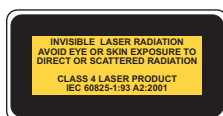

Your ideas are welcome.